

## SPECIFICATIONS

<b>Ranges:</b>	Dissolved Oxygen	0 to 20.0 mg/L (liter)
	Oxygen hi Air	0 to 100.0% O <sub>2</sub>
	Temperature	0 to 50°C
<b>Resolution:</b>	Dissolved Oxygen	0.1 mg/L
	Oxygen	0.1% O <sub>2</sub>
	Temperature	0.1°C
<b>Accuracy:</b>	Dissolved Oxygen	± 0.4 mg/L
	Oxygen	±0.7% O <sub>2</sub>
	Temperature	±0.8°C, ±1.5°F
<b>Probe Compensation and Adjustment:</b>	Temp:	0 to 50 °C, automatic
	Salt:	0 to 39% Salt
	Height	0 to 3900 meters

<b>Sampling Time:</b>	approximately 0.4 seconds
<b>Data Output:</b>	PC serial Interface
<b>Case:</b>	ABS plastic
<b>Fail safe:</b>	Low battery Indicator
<b>Power:</b>	one (1) 9-Volt alkaline battery
<b>Accessories Supplied:</b>	carrying case, oxygen probe, spare diaphragms (two), electrolyte for probe, battery, Traceable® Certificate, instructions.

FIGURE 1

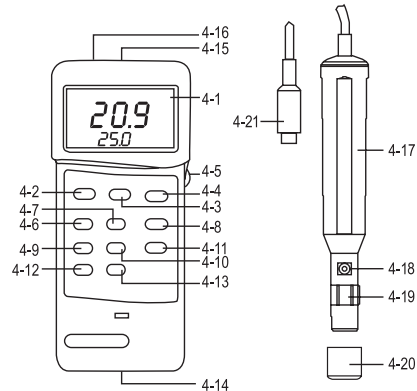

## DESCRIPTION

- 4-1 LCD
- 4-2 Power on/off Button
- 4-3 Data Hold Button: press to hold reading
- 4-4 °C/°F button
- 4-5 LCD contrast Adjustment Knob
- 4-6 Memory Record Button: press to record results.
- 4-7 Memory Recall Button: press to show minimum and maximum readings.
- 4-8 Factor Adjustment Button
- 4-9 Zero Button
- 4-10 % Salt Button
- 4-11 DO/O<sub>2</sub> Button
- 4-12 O<sub>2</sub> Calibration Button
- 4.43 Mountain Height Button
- 4-14 Battery Compartment
- 4-15 Probe Input Socket
- 4-16 Computer Output Socket
- 4-17 Oxygen Probe
- 4-18 Temperature sensor
- 4-19 Probe head with diaphragm
- 4-20 Protection cover for probe head
- 4-21 Oxygen Probe Plug

## DIGITAL OXYGEN METER OPERATION

1. This unit has been shipped with Electrolyte Liquid in the sensor. This enables the probe to correctly report oxygen. If calibrating the meter is difficult or if the meter readings are unstable, then it is possible that there is insufficient or no electrolyte in the sensor. **SEE REPLACING ELECTROLYTE** on how to fill the sensor.
2. Before use, the unit must be calibrated. Disconnect the OXYGEN PROBE PLUG (4-18, fig. 1) from the socket on top of the unit labeled INPUT (4-15, fig. 1).
3. Turn the meter on by switching the POWER BUTTON (4-2, fig. 1) to the right.
4. Select O<sub>2</sub> by sliding the O<sub>2</sub>/DO selector (4-11, fig. 1) to this position.
5. Press the ZERO BUTTON (4-9, fig. 1). The display will show 0.
6. Connect the OXYGEN PROBE PLUG (4-18, fig. 1) to the socket on top of the unit labeled INPUT (4-15, fig. 1). Wait at least five (5) minutes until the displayed values stabilize and no longer fluctuate.
7. Press the O<sub>2</sub> CALIBRATION BUTTON (4-12, fig. 1). The display will show either 20.8 or 20.9, the typical oxygen percentage in the air.  
**NOTE: Calibrate the meter in a large, well ventilated environment for best results.**
8. To measure Dissolved oxygen, slide the O<sub>2</sub>/DO selector (4-11, fig. 1) to the DO position.
9. Depending on your application, you may need to adjust the % salt compensation of the probe. Press % SALT BUTTON (4-10, fig. 1). The Display will show an "S" for salinity, and 0%. Press the FACTOR ADJUSTMENT BUTTON (4-8, fig. 1) once. This will add 1% to the original salt %. Continue pressing this button until it reaches the desired value. When complete, press % SALT BUTTON (4-10, fig. 1).
10. If your measurement is not taking place at sea level, you will need to adjust the Height compensation. Press the MT BUTTON (4-13, fig. 1) The Display will show an "H" for height and a 0 for zero sea level. Press the FACTOR ADJUSTMENT BUTTON (4-8, fig. 1) once. This will add 100 meters. Continue pressing this button until it reaches the desired value. When complete, press MT BUTTON (4-13, fig. 1).
11. Immerse the probe at least 10 cm into the liquid being measured. This ensures that the probe will measure the temperature of the liquid and the automatic temperature adjustment will take place. Allow a few minutes for the probe temperature reach the temperature of the liquid. If there is more than a few degrees of difference between the temperature of the liquid and the probe, allow more time for the probe temperature to adapt.
12. To measure the dissolved oxygen content, the velocity of the liquid being measured must be at least 0.2-0.3 m/s. To achieve this, immerse the probe in the solution and gently shake it. For a more accurate measurement, use a magnetic agitator to

ensure a certain velocity. Indicate that the value is a "held" value. To cancel the data hold feature, simply press the HOLD BUTTON a second time.

13. After use, rinse the probe thoroughly with tap water.

## DATA HOLD

To hold a measurement on the display, press the HOLD BUTTON (4-3, fig. 1) while a measurement is being taken. The LCD will show DH in the upper left portion of the display to indicate that the value is a "held" value. To cancel the data hold feature, simply press the HOLD BUTTON a second time.

## DATA RECORD

1. To record a measurement, press the RECORD BUTTON (4-6, fig. 1) while a measurement is being taken to hold the displayed value. The LCD will show REC in the lower left portion of the display to indicate that the value is being recorded. To deactivate the record function, press the RECORD BUTTON again.
2. Memory Recall: Use the RECALL BUTTON (4-7, fig. 1) to recall the minimum and average readings. When the REC symbol appears on the display, press the RECALL BUTTON (3-6, fig. 1) once. The maximum recorded value will be displayed. The letters "Max" will also appear on indicating that this is the maximum or highest reading. A second press of the RECALL BUTTON will display the minimum reading. The letters "Min" will also appear indicating that this is the minimum or lowest reading. A third press of the RECALL BUTTON will display the average reading. The letters "Avg" will also appear indicating that this is the average reading. Note: The Data Record function must be in use to utilize the Memory recall features. Once the RECORD BUTTON has been pressed a second time to deactivate the data record function, the minimum, maximum and values are no longer stored.

## AUTOMATIC SHUT-OFF

The unit has an automatic shut off feature to prolong battery life. If no button on the unit is pressed for ten minutes, the unit will automatically shut off. To deactivate this feature, press the RECORD BUTTON while a measurement is being taken.

## DISPLAY CONTRAST ADJUSTMENT

The Contrast of the LCD may need to be changed either because of light conditions, battery voltage drop, or user preferences. The LCD contrast can be adjusted using the LCD CONTRAST ADJUSTMENT KNOB (4-5, fig. 1). Simply turn the knob to the left or right until the optimal LCD contrast is obtained. If the display is filled with "88888" when no reading is being taken, the contrast needs to be adjusted. Turn the contrast knob to the left until a single "0" appears.

## RESETTING THE CPU SYSTEM

Certain incorrect operational procedures may disrupt the meters CPU system. If the meter is not working properly, the circuit may need to be reset. Set the DO/O<sub>2</sub> switch to O<sub>2</sub> (4-11, fig. 1). Turn off the meter by pressing the power button (4-2, fig. 1). Disconnect the probe from the meter. Press the O<sub>2</sub> CALIBRATION BUTTON (4-12, fig. 1) continuously. While still pressing this button, press the power button again. Then press the zero button (4-9, fig. 1). Reconnect the probe and wait until the reading stabilizes. Press the O<sub>2</sub> CALIBRATION BUTTON (4-12, fig. 1) again. Turn the power off. Begin normal operating procedures again.

FIGURE 2

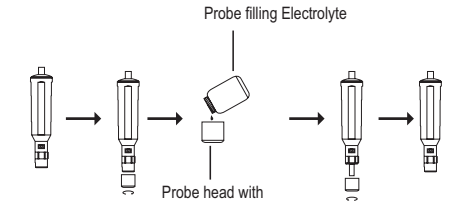

## REPLACING THE ELECTROLYTE

1. When the meter cannot be calibrated properly or if the reading is unstable, the electrolyte may need to be refilled or the diaphragm may be dirty and need to be replaced. Unscrew the Probe Head (8-3, fig. 2)
2. Pour out the old electrolyte from the Probe Head (8-3, fig. 2).
3. Pour in the new Electrolyte into the container of the probe head.
4. Reassemble the Probe Head (8-3, fig. 2) with the Probe Body (8-1, fig. 2).

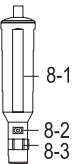

#### COMPUTER OUTPUT

This unit features computer output. A COMPUTER OUTPUT SOCKET (4-10, fig. 1) is located on the top of the unit. To utilize this feature, connect the unit to a PC with the Data Acquisition Accessory. (SEE ACCESSORIES SECTION).

#### BATTERY LIFE

If the letters "LBT" appear on the left corner of the display, it indicates the battery is low and needs to be replaced. To replace the battery, slide the battery cover located on the back of the unit away from the unit. Remove the old battery and replace it with a new 9-Volt alkaline battery. Use an alkaline battery, NOT a regular or heavy duty battery. Properly connect the battery. Replace the battery cover. Incorrectly installed batteries may damage electronics.

#### ALL OPERATIONAL DIFFICULTIES

If this oxygen meter does not function properly for any reason, please replace the battery with a new 9-Volt alkaline batteries (see Low Battery section). Low battery power can occasionally cause any number of "apparent" operational difficulties. Replacing the batteries with new fresh batteries will solve most difficulties.

#### ACCESSORIES

**Cat. No. 4138**

**Easy-Use™ Accessory Adaptor 115 VAC**

**Cat No, 4136**

**Data Acquisition System Accessory** Powerful and easy to use computer data capture/data logging program works with Traceable® Instruments with computer output. Records interval readings from 1 to 10,000 seconds; displays minimum/maximum readings; and utilizes an alarm mode that permits the user to be notified visually, audibly, and by email when an alarm is triggered. Data is stored to a file that can be printed in any report or spreadsheet format. Networking server/client capability allows the captured data to be monitored on a remote workstation and/or by email. It is designed to work with Windows® 98/Me/NT/2000/XP/Vista. Includes a CD, a 6-foot cable (supplied USB and serial connections) that plugs into the instrument and computer. Accessory extension cables expand cable length to 300 feet.

**Cat. No. 4326**

**Accessory Adaptor 115 VAC for Data Logger**

#### WARRANTY, SERVICE, OR RECALIBRATION

For warranty, service, or recalibration, contact:

#### TRACEABLE® PRODUCTS

12554 Old Galveston Rd. Suite B230  
Webster, Texas 77598 USA  
Ph. 281 482-1714 • Fax 281 482-9448  
E-mail support@traceable.com  
www.traceable.com

Traceable® Products are ISO 9001:2018 Quality-  
Certified by DNV and ISO/IEC 17025:2017  
accredited as a Calibration Laboratory by A2LA.

## TRACEABLE® DIGITAL OXYGEN METER INSTRUCTIONS